



Guidance document GD 19

April 2015

EFFECTIVE SEALING OF END LAP DETAILS IN METAL ROOFING CONSTRUCTIONS

1 INTRODUCTION

This guidance document introduces the reader to key issues that need to be addressed to ensure the effective sealing of end laps in metal roofing constructions. The guidance covers the following combinations:

- Profiled metal to metal
- Profiled metal to rooflight
- Sandwich panel to panel
- Sandwich panel to factory assembled rooflight.

This guidance document is an updated version of MCRMA technical paper No 16 and the information contained within this document is intended to provide generic guidance on improved sealing of end lap details. The information was compiled through a study involving a carefully selected cross-section of built up and composite roofing profiles (including their rooflight counterparts) believed to represent those most commonly used within the UK and has been restricted to end lap details of 150mm (see Appendix for details of this study).

Although this was not an exhaustive study, it is believed that the cross-section of profiles and system types involved, allows the resulting guidance to be applicable for most of the built-up and insulated profiles available in the United Kingdom. It is stressed, however, that sealing specifications for specific profiles and systems should still be sought from individual manufacturers.

The guidance should be read in conjunction with each manufacturer's own instructions which must be followed together with their sealing specifications for specific profiles and systems.

2 PRINCIPAL GUIDANCE DETAILS FOR SEALING END LAPS

The effective sealing of end lap configurations using butyl strip sealant is a careful balance between the size of the butyl strip sealant, the proximity of the sealant relative to the primary fixings and the number and positioning of the primary fixings. Inadequately sized or positioned sealant, and/or insufficient or incorrectly positioned fixings, will result in poor sealing of the end lap detail.

2.1 Sealant size, shape and position

In general, the most important dimension of a butyl strip sealant with regard to its ability to seal end lap details is its height. A sealant should be suitably sized to enable it to provide a continuous seal across the entire width of the profile sheet. Tables 1 and 2 provide guidance on the selection of suitable size and shapes of butyl strip sealant for sealing end lap details in built-up and insulated panel roofing systems.

Built up systems	Size, shape and position of sealant(s)
Profiled metal to metal combinations	<p>Two lines of sealant (central or asymmetric primary fixing position)</p> <p>A single run of 6 x 5mm or 6mm Ø bead sealant positioned 15mm from each end of the lap.</p>
Profiled metal to rooflight combinations	<p>Two lines of sealant (asymmetric primary fixing position)</p> <p>A single run of 6 x 5mm or 6mm Ø bead sealant positioned approximately 10-15mm either side of the primary fixing*</p> <p>Or alternatively,</p> <p>Three lines of sealant (central primary fixing position)</p> <p>A single run of 6 x 5mm or 6 or 8mm Ø bead sealant positioned 15mm from each end of the lap with an optional 18 x 4 or 22 x 5mm U-section positioned beneath the line of the primary fixing</p>

Table 1: Built-up systems - size, shape and position of sealant(s) for typical 150mm end lap details

Insulated panel systems	Size, shape and position of sealant(s)
Insulated panel to panel combinations	Three lines of sealant (asymmetric primary fixing position) A single run of 6 x 5mm or 6mm Ø bead sealant positioned approximately 10-15mm either side of the primary fixing with a third seal positioned 15mm from the bottom of the lap.
Insulated panel to factory assembled rooflight combinations	Two lines of sealant (asymmetric primary fixing position) A single run of 6 x 5mm or 6mm Ø bead sealant positioned approximately 10-15mm either side of the primary fixing*

Table 2: Insulated panel systems - size, shape and position of sealant(s) for typical 150mm end lap details

** Where a seal is required at the bottom of the lap to keep out dirt and trapped water a bead of premium quality neutral cure silicone sealant positioned approximately 15mm from the bottom of the lap is suggested. The silicone sealant should ideally conform to classification ISO 11600- F-25 LM of BS EN ISO 11600: 2003 and adhesion to the substrates involved verified.*

To obtain the best performance from the above sealant configurations, it is important that the number and position of primary fixings are sufficient to apply compression to the sealant across the full width of the profile sheet. Failure to use sufficient or incorrectly positioned fixings may affect the sealing ability of the sealant used.

3.0 FIXINGS

One of the earliest factors identified as playing an important role in the effective sealing of end lap details are the number and position of fixings used. The purpose of the fixing with respect to sealing efficiency is to apply sufficient pressure to the sealants so that they provide continuous condensation and weather seals across the entire width of the profile.

Testing has shown that the performance of many of the sealant configurations whether for built-up or insulated panel profiles could be improved by using sufficient fixings distributed evenly across the width of the profile. Trials also showed that the optimum compression of many of the sealant options was achieved by the use of a single fixing positioned centrally in every trough of narrow profiles and two fixings positioned evenly across the trough of wide profiles (see figures 1 and 2).

Insufficient number or poorly positioned fixings will commonly result in inadequate pressure being applied to the sealant, most noticeably at the corners formed between the horizontal pan and sloped sides of the trough section, and often accompanied by a visible bowing on wider profiles.

The effect of crown fixing was also evaluated across a small number of profiles and shown to be much less effective than trough fixing, again especially when used to fix wider profile widths and should be avoided at end lap details.

3.1 Primary fixings

The purpose of the primary fixings regarding sealing efficiency is to apply sufficient compression to the sealants so that they effect a continuous seal across the entire width of the profile. Due to differences in the design of profiles available, the number and position of fixings required to effect a complete seal varies. However, investigation has shown that optimum compression of a suitably sized sealant in end lap details may be achieved if the following number and position of fixings are adopted:

3.2 Narrow profiles

Ideally, a single fixing should be positioned as evenly as possible across the profile sheet and central to each trough (see figure 1)



Fig 1: Position of fixings across a narrow profile (minimum 4 major troughs)

3.3 Wide profiles

Two fixings are suggested positioned as evenly as possible across the profile sheet and ideally in the trough adjacent to the major crown as shown in figure 2.



Fig 2: Position of fixings across a wide profile (3 or less major troughs)

Crown fixing has been shown to have poor performance across a wide selection of profiles and should be avoided at end lap detail.

4.0 POSITION OF SEALANTS

An important factor that has a major effect on the effective sealing of end laps is the position of the sealant relative to the primary fixing. Observations show that as the sealant is moved further away from the fixing, the compression applied to the sealant diminishes. Trials have clearly shown that the closer the sealant is positioned to the fixing, the better the compression and hence the better the end lap is sealed to external elements.

The main purpose of a sealant within an end lap is to provide effective weather and condensation seals. Many of the current recommendations for sealing between metal to metal end lap details in built-up and insulated panel systems call for a run of sealant to be positioned towards the bottom of the lap in order to minimise the amount of water retained by capillary action. However, careful positioning of sealant at this location is required in order to prevent the sealant from extruding out of the lap when compressed.

Clearly, in order to achieve both the above criteria, the sealant should be positioned close to the end of the lap yet not too far away from the primary fixing that it is insufficiently compressed to affect a seal. However, trials show that achieving both criteria can at times be difficult especially in lap configurations where the primary fixings are positioned at opposite ends of the lap to the bottom run of sealant. Lap configurations with more centrally positioned primary fixings have been shown to achieve the above criteria more consistently when using a suitably sized sealant.

4.1 Built-up systems

Some existing recommendations call for end lap details to be sealed by positioning a single run of sealant towards the upper edge of the lap (condensation seal) and a single run of sealant positioned towards the lower edge of the lap (weather seal).

A noticeable difference observed between existing recommendations for built-up systems appears to be the position of the primary fixing. Some recommendations have an asymmetric design where the fixing is positioned typically towards the top third of the lap. This design has been shown to apply most of its compression to the sealant(s) positioned towards the top of the lap and less compression to sealant positioned towards the bottom of the lap. By comparison, the symmetrical design of a centrally fixed end lap detail allows the fixing to apply more or less equal pressure to the sealants positioned at the upper and lower ends of the lap and has been shown to be more effective at providing continuous seals.

However, testing indicates that so long as the primary fixing are positioned no closer than 50mm to the top of a 150mm lap then continuous condensation and weather seals can be achieved by the use of a suitably sized and shape of sealant.

The crucial dimension of a sealant in respect of its sealing ability has been identified as its height. For the range of profiles used in this test programme, a sealant of less than 5mm in height appears challenged at providing continuous seals, whereas sealants of 5 or 6mm in height, namely 6 x 5mm (see notes below) and 6mm Ø bead, appear to be the optimum height and provide excellent results. Sealants of greater than 6mm in height have been identified as serving only to hold panels apart and are less desirable.

Notes:

- The sealant should be positioned sufficiently back from the leading edge of the lap to prevent extrusion from the joint when compressed. In the case of 6 x 5mm or 6mm Ø bead this is ideally 15mm, dependant on the profile.
- Inspection of various sites using 6 x 5mm sealant for both end and side laps have shown that a good seal is achieved along the side laps and at the junction of a 4-way joint between profile metal sheeting (providing the correct order of sheet laying and sealant application is adopted (see figure 3)).
- In addition to its sealing ability the 6 x 5mm section has excellent reel stability (a property controlled by the width of the sealant), which makes it more robust to the rigours associated with roofing and hence more acceptable to the contractor than the alternative round sections.

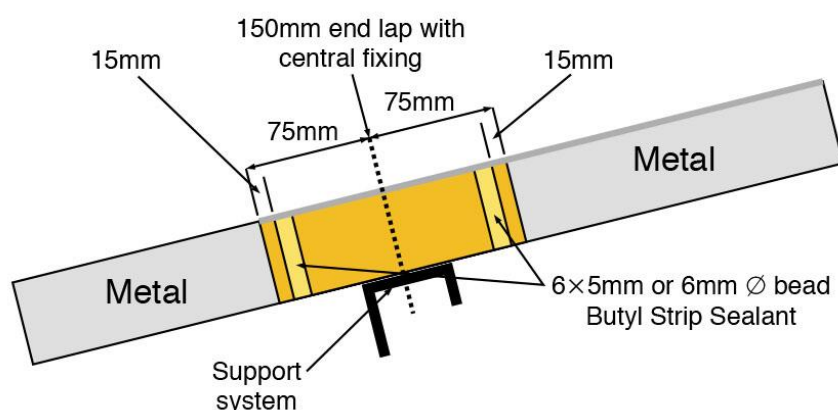

Fig 3: Single skin end lap detail (metal over metal)

4.2 Insulated panel systems

The design of many insulated panel system end laps and especially those evaluated in these trials have a through fixing positioned typically 25mm from the top of the lap. The asymmetrical position of this fixing, as detailed earlier, results in a majority of its pressure being applied towards the top of the lap with less pressure applied to the bottom of the lap.

There are various recommendations given for sealing insulated panel systems. Some recommendations simply call for two seals; one seal positioned towards the top of the lap with a second seal positioned towards the bottom of the lap. Other recommendations call for three seals; comprising of two seals approximately 10-15mm either side of the main through fixing with a third run of sealant positioned towards the bottom of the lap.

As with built-up systems, testing shows that the crucial dimension of a sealant with respect to its sealing ability is its height. For the range of profiles evaluated, a sealant of less than 5mm in height appears challenged at providing continuous condensation and weather seals; whereas sealants of 5mm or 6mm in height, namely 6 x 5mm and 6mm Ø bead appear to be the optimum size of sealant and provide improved sealing performance. Sealants of greater than 6mm in height again serve to hold panels apart and are less desirable.

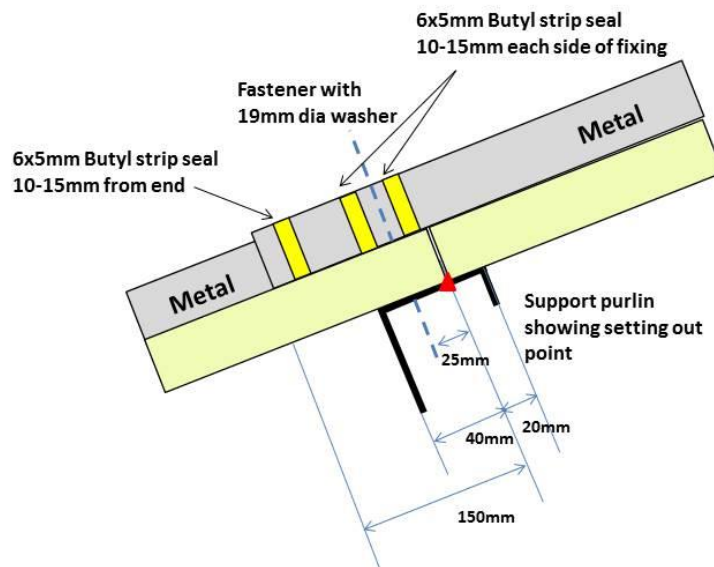

Fig 4: Insulated panel end lap detail (metal over metal)

4.3 Rooflights

By nature of their composition, rooflights, whether single skin or of factory assembled twinskin construction are inherently more flexible than their metal panel counterparts. In addition, the profiling of many rooflights is observed to have corners with greater radii than their metal counterparts. This often results in the presence of larger and more variable gaps between most rooflight and metal profile sheet combinations than is typically experienced between two sheets of theoretically identical profiled metal sheeting.

4.3.1 Single skin rooflight /profile metal sheeting built-up combinations

There are various recommendations given for sealing end lap detail between metal and translucent profiled sheeting.

Some recommendations call for two seals comprising of a single run of sealant positioned approximately 10-15mm either side of the fixing.

Other recommendations call for three seals, comprising of a single run of sealant positioned towards the top and bottom of the lap with an additional run of sealant positioned beneath the line of the central fixing.

The performance of recommendations calling for two seals positioned approximately 10-15mm either side of the fixing shows that butyl sealants of 5 or 6mm in height are required to provide effective sealing performance.

Sealants of less than 5mm in height appear unable to provide a complete seal even though receiving maximum compression due to their close proximity to the fixing. In this configuration the performance of two runs of sealant of greater than 6mm in height was observed to be poor and contributed to increased deflection of the rooflight resulting in 'bird mouting' at the bottom end of the lap.

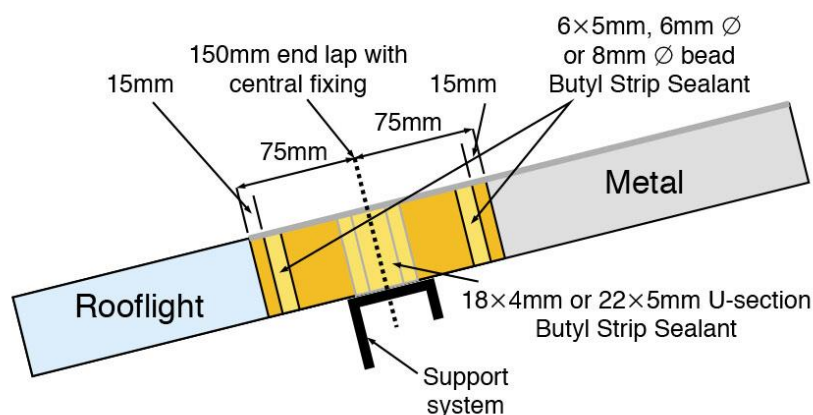

Fig 5: Built-up system end lap detail (metal over rooflight) 3 runs of butyl sealant

Where a seal is required at the bottom of the lap to keep out dirt and trapped water, a bead of premium quality neutral cure silicone sealant positioned approximately 15mm from the bottom of the lap is suggested. The silicone sealant should ideally conform to classification ISO 11600-F-25 LM of BS EN ISO 11600: 2003, *Classification and requirements of sealants and its adhesion to the substrates involved verified*. Due to its soft paste like consistency in the uncured state, a silicone sealant lends itself to accommodating variable joint thickness and does not require the same compression as a butyl sealant to effect a seal.

Evaluation of an alternative sealing recommendation using a central primary fixing position has shown that good sealing performance may be achieved by the use of three runs of sealant. A single run of suitably sized sealant (6 x 5mm, 6 or 8mm Ø bead) positioned towards the top and bottom of the lap detail was found to provide effective condensation and weather seals. The inclusion of a U-section (typically 18 x 4mm or 22 x 5mm) positioned beneath the line of the central fixing provides support to the rooflight and reduces the effect of deflection associated with the fixing position.

Note:

Where a 4-way joint between the rooflight over profile sheets to combination exists, the sealant used for the side laps must be capable of sealing large variations in joint thickness. To this end, it is felt that a minimum 6mm or possibly 8mm Ø bead may be required to effectively seal side laps.

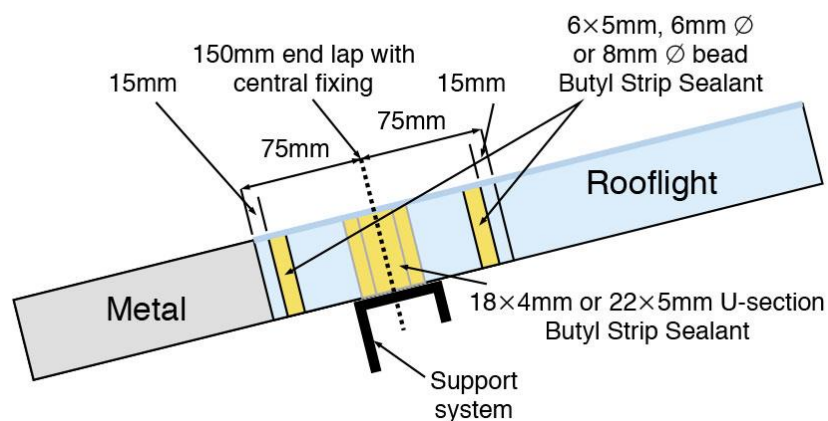

Fig 6: Built-up system end lap detail (rooflight over metal) 3 runs of butyl sealant

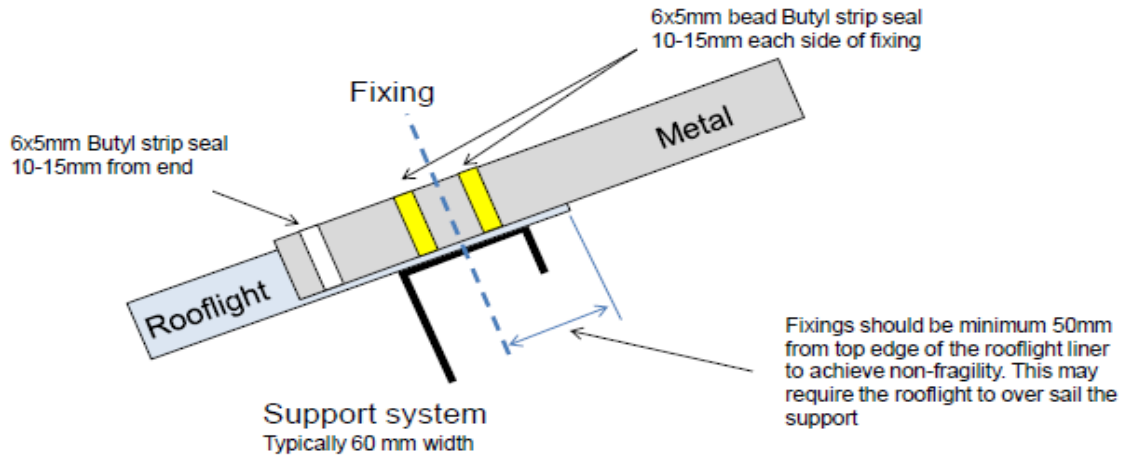

Fig 7: Built-up system end lap detail (metal over rooflight) 2 runs of butyl sealant

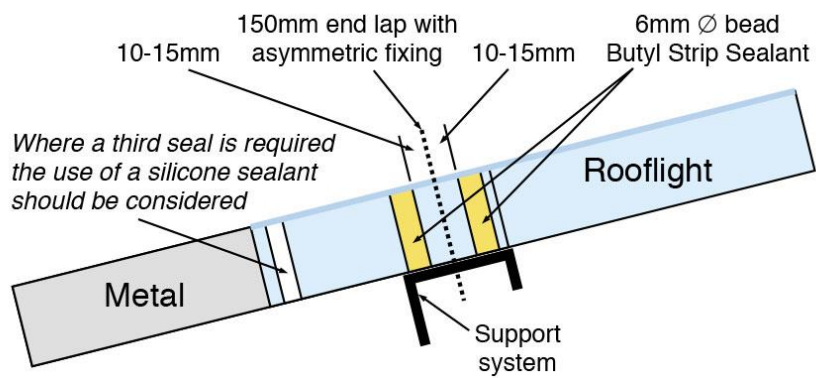

Fig 8: Built-up system end lap detail (rooflight over metal) 2 runs of butyl sealant

4.3.2 Factory assembled twin-skin rooflight/insulated panel combinations

Various recommendations exist for end lap details between factory assembled rooflights and insulated panel combinations. Some recommendations call for three seals, comprising typically, of two seals positioned approximately 10-15mm either side of the fixing towards the top of the lap with a third run of sealant positioned towards the bottom of the lap, whilst others omit the requirement for the third seal.

Whilst the use of a suitably sized sealant such as 6 x 5mm or 6mm Ø bead has shown to provide excellent sealing when positioned close to the line of fixing, a butyl sealant used to seal at the bottom end of the lap has been shown to be ineffective. The main factors believed to be responsible for the ineffective bottom seal when using a butyl sealant are:

- The lack of compression that can be applied to a sealant at the bottom of a lap by a fixing positioned towards the top of a lap.
- Discrepancies in fit between the rooflight and metal profiled materials.
- The intrinsic flexibility of rooflights

As with single skin rooflights, where a seal is required at the bottom of the lap to keep out dirt and trapped water, a bead of premium quality neutral cure silicone sealant positioned approximately 15mm from the bottom of the lap is suggested. The silicone sealant should ideally conform to classification ISO 11600- F-25 LM of BS EN ISO 11600: 2003, *Classification and requirements of sealants and its adhesion to the substrates involved verified*. Due to its soft paste-like consistency in the uncured state, a silicone sealant lends itself to accommodating variable joint thickness and does not require the same compression as a butyl sealant to effect a seal.

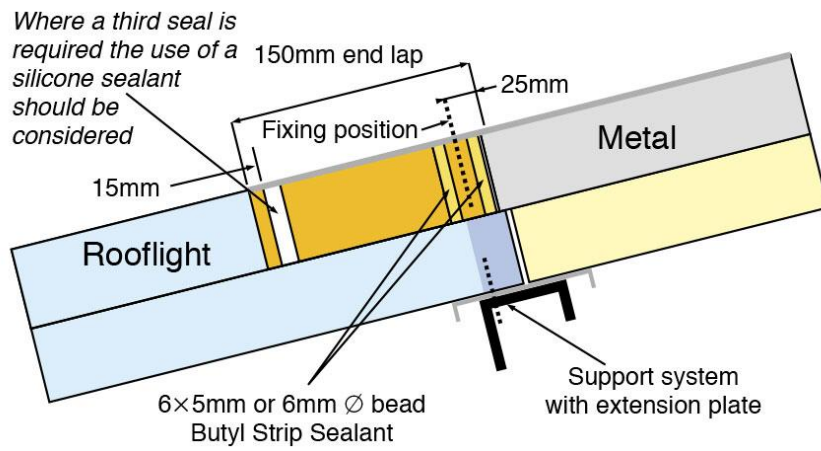

Fig 9: Insulated panel end lap detail (metal over rooflight)

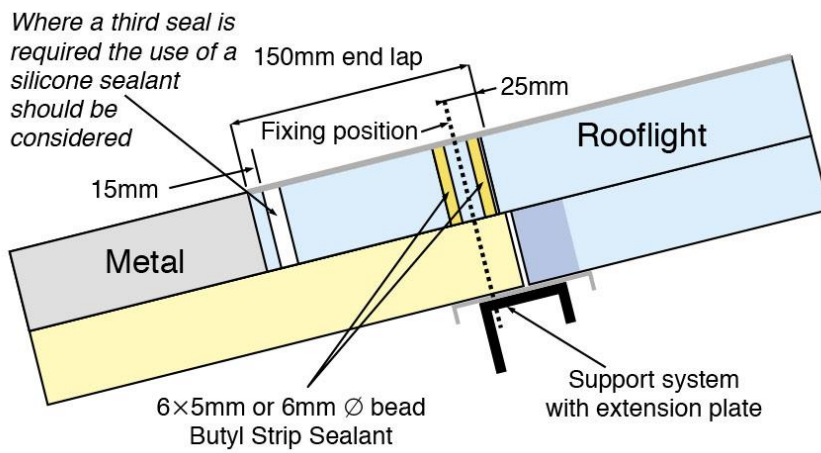

Fig 10: Insulated panel end lap detail (rooflight over metal)

5.0 CONCLUSION

It is essential to ensure that the side and end laps of the roofing and cladding system and perimeter joints are correctly sealed and well installed. This will lessen air leakage, provide vapour control and retain heat. Getting it wrong at the construction stage will cause a building to fail, resulting in expensive remedial work.

Manufacturers are best placed to offer advice about their particular products and any variation from their published data during the design or construction process could result in the component or system failing prematurely. Any uncertainty about the use or application of a product or system should be referred back to the manufacturer for detailed written advice.

Additional project specific advice for demanding or complex constructions may also be obtained from one of the independent consultants featured on the MCRMA web site at www.mcrma.co.uk.

APPENDIX

This guidance document resulted from a report on the findings/observations made during an evaluation into the effective weather sealing of typical end lap details between external metal to metal sheeting and metal to rooflight for through fixed built-up and insulated panel roofing systems.

Hodgson Sealants Limited (now H S Butyl Limited) was approached by the MCRMA to facilitate a test programme to further investigate these issues across a wider range of typical roofing systems. Support for the project came from a wide cross-section of members keen to become active partners offering support in the form of materials, expertise and assistance with testing and included:

- Sealant manufacturers
- Fixing suppliers
- Roofing and cladding industry consultants
- Painted metal manufacturers
- Profile metal and insulated panel manufacturers
- Rooflight manufacturers
- System suppliers (built-up and insulated panel systems)
- Roofing contractors

PROJECT SCOPE

To identify best practice and materials for providing an effective weather seal across a range of typical external metal to metal and metal to rooflight end lap details for through fix built-up and insulated panel roofing systems. The test programme was split into three stages as follows:

Stage 1

Evaluate the effectiveness of current practice, manufacturers' recommendations and sealants used in sealing the end lap details as described above.

Stage 2

Evaluate alternative sealing recommendations to improve upon current practice where necessary.

Stage 3

Larger scale evaluation of a restricted number of joint configurations from stages 1 and 2 shown to improve weather sealing performance of the end lap details.

Note:

Whilst stages 1 and 2 were carried out under controlled laboratory conditions far removed from the varied and usually adverse environmental conditions encountered on site, it was acknowledged that what could not be made to work under laboratory conditions would more than likely not work on site either.

Acknowledgment:

This research project was carried out by Hodgson Sealants Limited on behalf of the MCRMA.

NOTE:

This guidance document replaces MCRMA Technical Paper No 16 *Effective sealing of end lap details in metal roofing constructions* published February 2004

REFERENCES

C A Building Products Limited, *Twin-Therm™ Roof & Wall System Technical Data*

C A Building Products Limited, *Twin-Therm™ Roof and Wall Installation Guide*, June 2002
Version 1

C A Building Products Limited, *Twin-Therm™ Roof Non-Fragility Fixing Specification*,
November 2002

C A Group Ltd, *Twin-Therm™ Roof System*, British Board of Agrément, Certificate
No.98/3518

Filon Products Limited, *Filon FADS and FADSAFE-Factory Assembled Double Skin
Rooflights*, Data Sheet CI/SfB 37 Nn 8, September 1999.

Filon Products Limited *Guide to the use of Filon GRP Rooflights to meet HSE
Construction (Design and Management) Regulations 1994 (CDM)*, Data Sheet CI/SfB
37 Nn8, June 2001

Hartington Conway Limited, *Installation of Site Assembled In-plane Rooflights (GRP)*,
Technical Bulletin 126, Jan 2002

Hartington Conway Limited, *Installation of Factory Assembled Insulating Rooflights (GRP)*,
Technical Bulletin 125, July 2002

National Federation of Roofing Contractors Limited, *Profiled sheet roofing and cladding. A
guide to good practice*, Third Edition, 1999

The Metal Cladding & Roofing Manufacturers Association Limited, *Fasteners for Metal Roof
and Wall Cladding: Design, Detailing and Installation Guide*, Technical Paper No 12, May
2000

The Metal Cladding & Roofing Manufacturers Association Limited, *Guidance for the Design
of Metal Roofing and Cladding to Comply With Approved Document L2: 2001*, Technical
Paper No 14, January 2002

DISCLAIMER

Whilst the information contained in this document is believed to be correct at the time of publication, the Metal Cladding and Roofing Manufacturers Association Limited and its member companies cannot be held responsible for any errors or inaccuracies and, in particular, the specification for any application must be checked with the individual manufacturer concerned for a given installation.

Information provided by the MCRMA or contained within publications and articles which are made available in any form (mechanical, electronic, photocopying or otherwise) cannot be used or cited as a means of ensuring that a material, product, system or assembly is compliant with Building Regulations.