

GET IT RIGHT FIRST TIME!

Good installation practice on site starts with the correct selection of materials from a reputable manufacturer who should then be regarded as the primary source for advice about installation procedures and processes. This article looks at some of the common installation issues encountered on site and how, by following good practice guidelines, problems can be avoided.

Air-tightness requirements mean that the effective side and end lap sealing of lining sheets in built-up cladding systems is key. The sealing of side laps on lining sheets also contributes towards the effective sealing of the building against the transfer of vapour from the inside of the building into the cavity.

During the site assembly of built-up cladding systems the side laps of the joints between adjacent lining sheets must be sealed adequately using 50mm x 1mm foil tape. The sealing strip must lap either side of the side joint and must be in full and bonded contact along the length of the sheet. Cold or damp site conditions can affect the adhesive properties of the tape; therefore ensure that the foil tape is “brushed down” onto the joint before the insulation is laid.

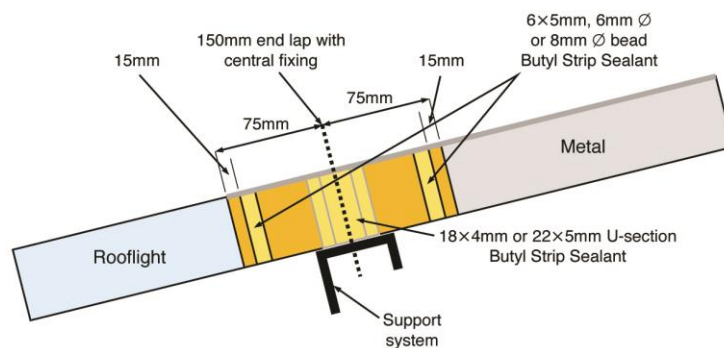

Built up system end lap detail (metal over GRP rooflight), three runs of butyl sealant

The end lap of lining sheets must be fully sealed to provide adequate air and vapour sealing. Butyl strip should be positioned within the end lap in a continuous unbroken length and it should form around the shape of the profile without stretching. Particular care should be taken at corners and junctions to ensure continuity of the seal. To complete the end lap joint a series of fasteners should be inserted through the lap into the underlying purlin to pull the joint together and provide fixture for the lining panels.

The position and size of butyl mastic seal in the overlap joints of outer sheets can have a significant effect on the overall performance and weather tightness of profiled roofing and cladding systems. The sealing strip is introduced into the lap to prevent the ingress of dirt and water from the weather side and to prevent the potential risk of condensate from entering the top of the lap from the inside.

The sealing strip or bead must be in full contact with both surfaces of the joint; it must be flexible enough to deform around the shape of the profile, resilient enough not to compress excessively under load and yet be flexible enough to withstand movement within the joint. The expansion characteristics of the sealant must be able to accommodate the full movement of the joint and therefore must be specified accordingly. It must also last the life of the building without degrading or cracking.

Site assembled built-up cladding systems offer the advantage of being able to tailor the thermal and acoustic layers to meet the needs of the specific building. The correct installation of insulation quilt in built-up cladding systems will result in a more thermally and acoustically efficient building. The design process assumes that the individual strips and elements of the insulation quilt are closely butted and form a continuous and unbroken layer across the whole surface of the building, including corners and junctions, thus ensuring all voids and gaps are filled with quilt insulation. It also assumes that the insulation layers rise to their full thickness without leaving a gap under the top sheet.

The insulation needs to fully fill the cavity and the top sheets should rest on the insulation or slightly compact the insulation when fixed. The insulation must not be permanently compressed or deformed locally as to adversely influence the final performance.

Built-up cladding systems rely on the need to provide and maintain a space between the inner lining and the outer sheet of the system to accommodate the insulation layer. The stand-off distance is governed by a spacer system comprising a structural bar and a series of structural posts or brackets. The posts are available in a range of different heights to suit the uncompressed depth of the specified insulation. Spacer systems not only provide a stand-off dimension but also transfer the applied loads from the outside of the building onto the primary and secondary internal structure.

The posts of the spacer system are positioned along the length of the structural bar and are attached at their base through the lining sheet and into the purlin with the required number of fasteners. The fasteners, which form a structural part of the total system, must fully engage into the top flange of the purlin. Some types of spacer system require additional structural bracing to accommodate particular loading conditions and manufacturers' recommendations should be followed.



Approximately 40 percent of fasteners on industrial/commercial buildings are used in an exposed situation and will require weather sealing. However, the installation process can sometimes have an adverse influence on the final performance; one of the principal causes of failure is the miss-drilling of primary fasteners through the external weather skin resulting in the fastener not engaging into the underlying purlin or spacer. This will result in the fastener spinning, not fully compressing the sealing washer and hence the fastener will leak.

Primary fasteners must be drilled through the top sheet within the area of the top flange of the purlin or spacer. Purlins can rotate and sag under certain loading conditions or if sag rods have not been installed during the erection process. This will result in misalignment of the purlin and the increased possibility of miss-drilling of primary fasteners. Loose miss-drilled fasteners should be removed at the time of installation and corrective action taken.

Detailed installation guidelines can be found on the MCRMA web site and independent advice can be obtained from design and build consultants featured within the Consultants section of the MCRMA web site.

This article first appeared in RCI Magazine, March 2012

DISCLAIMER

Whilst the information contained in this publication is believed to be correct at the time of publication, the Metal Cladding and Roofing Manufacturers Association Limited and its member companies cannot be held responsible for any errors or inaccuracies and, in particular, the specification for any application must be checked with the individual manufacturer concerned for a given installation.

Information provided by the MCRMA or contained within publications and articles which are made available in any form (mechanical, electronic, photocopying or otherwise) cannot be used or cited as a means of ensuring that a material, product, system or assembly is compliant with Building Regulations.